

Pressure sensor with ceramic and metal sensors

Cerabar PMC11 / PMP11



PMC11

PMP11



Complete product information:
www.e-direct.endress.com/pmx11

- High reproducibility and long-term stability
- Customized measuring ranges
- Flush-mounted process connection as option

i Specs at a glance:

- **Media:**
Gases, vapors, liquids and dust
- **Output:**
4 to 20 mA, 0 to 10 V
- **Process temperature:**
-25 to +85 °C (-13 to +185 °F)
- **Measuring ranges:**
From -400 to +400 mbar
(-6 to +6 psi) to -1 to +40 bar
(-15 to +600 psi)
- **Reference accuracy:**
±0.5 %

Application The Cerabar is a pressure sensor for the measurement of gauge pressure in gases, vapors, liquids and dust. The Cerabar can be used in versatile applications thanks to a wide range of process connections.

Function

Ceramic process isolating diaphragm:

The ceramic sensor is an oil-free sensor, i.e. the process pressure acts directly on the robust ceramic process isolating diaphragm and causes it to deflect. A pressure-dependent change in capacitance is measured at the electrodes of the ceramic substrate and the process isolating diaphragm.

Metallic process isolating diaphragm:

The process pressure deflects the metal process isolating diaphragm of the sensor and a fill fluid transfers the pressure to a Wheatstone bridge (semiconductor technology). The pressure-dependent change in the bridge output voltage is measured and evaluated.

Application example

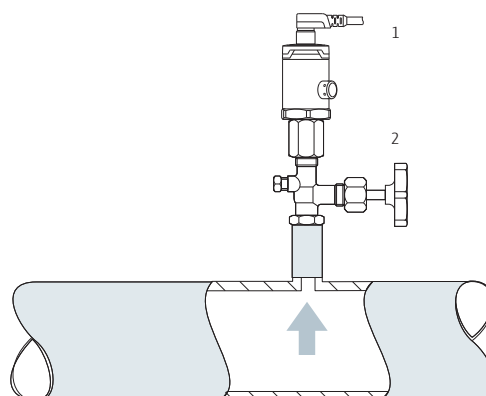

Pressure sensor Cerabar (1)
with the shutoff device (2)
in pipelines

Technical data

Output		Environment	
Output signal	4 to 20 mA (two-wire); 0 to 10 V (three-wire)	Ambient temperature range	-40 to +70 °C (-40 to +158 °F)
Signal range 4 to 20 mA	3.8 to 20.5 mA	Storage temperature range	-40 to +85 °C (-40 to +185 °F)
Load 4 to 20 mA	$R_{Lmax} \leq (U_B - 6.5 V) / 22 mA^{1)}$	Climate class	Class 3K5
Load resistance (for 0 to 10 V devices)	The load resistance must be $\geq 5 [k\Omega]$	Electromagnetic compatibility	- Interference emission as per EN 61326 equipment B - Interference immunity as per EN 61326 appendix A (industrial sector) - NAMUR recommendation EMC (NE21)
Signal on alarm 4 to 20 mA	max. alarm $>21 mA$	Process	
Dynamic behavior	Time constant (T_{90}) 15 ms	Process temperature range	-25 to +85 °C (-13 to +185 °F)
¹⁾ R_{Lmax} : maximum load resistance; U_B : supply voltage		Materials PMC11	
Power supply		Materials not in contact with process	Housing: Stainless steel 316L (1.4404)
Supply voltage	4 to 20 mA output: 10 to 30 V DC; 0 to 10 V output: 12 to 30 V DC	Materials in contact with process	Process connections: 316L (1.4435); Ceramic process isolating diaphragm: Al_2O_3 in accordance with FDA; TSE Certificate of Suitability for all device components in contact with the process; Seal: Viton FKM or EPDM
Current consumption	two-wire: $\leq 26 mA$; three-wire: $<12 mA$	Materials PMP11	
Degree of protection	IP65 NEMA Type 4X enclosure	Materials not in contact with process	Housing: Stainless steel 316L (1.4404); Filling oil: NSF-H1 synthetic oil in accordance with FDA 21 CFR 178.3570
Influence of power supply	$\leq 0.005 \%$ for URL/1 V	Materials in contact with process	Process connections: 316L; Metallic process isolating diaphragm: AISI 316L (1.4435); TSE Certificate of Suitability for all device components in contact with the process; With flush-mounted process isolating diaphragm: Seal: Viton FKM
Residual ripple	$\pm 5 \%$	Approvals	
Performance characteristics		Pressure Equipment Directive	
Reference accuracy	$\pm 0.5 \%$		
Thermal change of the zerooutput and the output span	$<1 bar (15 psi): <1 \%$; $\geq 1 bar (15 psi): <0.8 \%$		
Long-term stability	1 year: $\pm 0.2 \%$; 5 years: $\pm 0.4 \%$; 8 years: $\pm 0.45 \%$		
Switch-on time	$\leq 2 s$		

Dimensions in mm (inches)

Housing

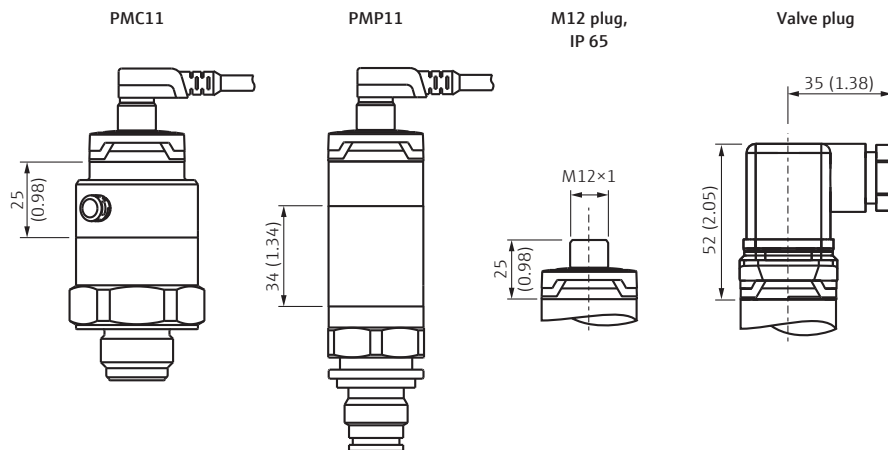

Installation according to instruction manual.

Dimensions process connections PMC11 in mm (inches)

Process connections with internal, ceramic process isolating diaphragm

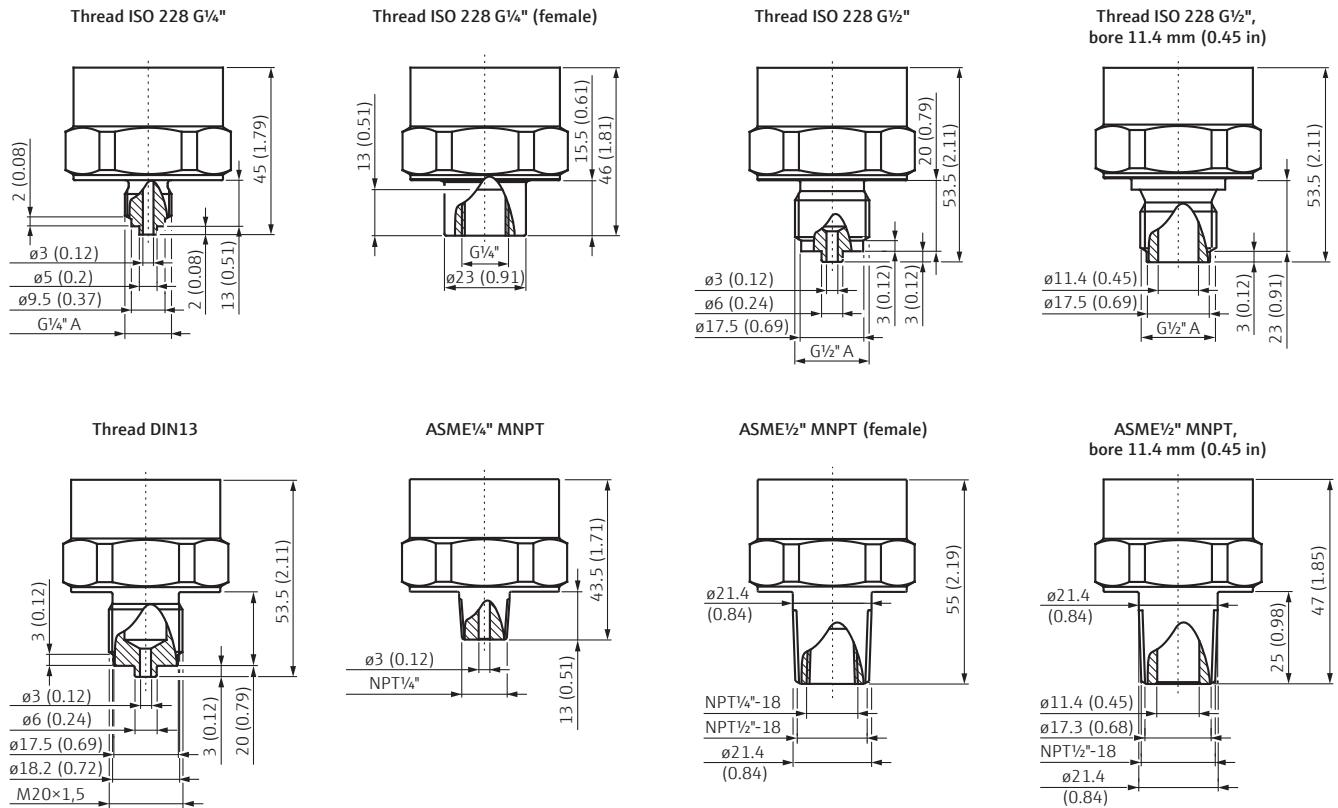

Dimensions process connections PMP11 in mm (inches)

Process connections with internal, metallic process isolating diaphragm

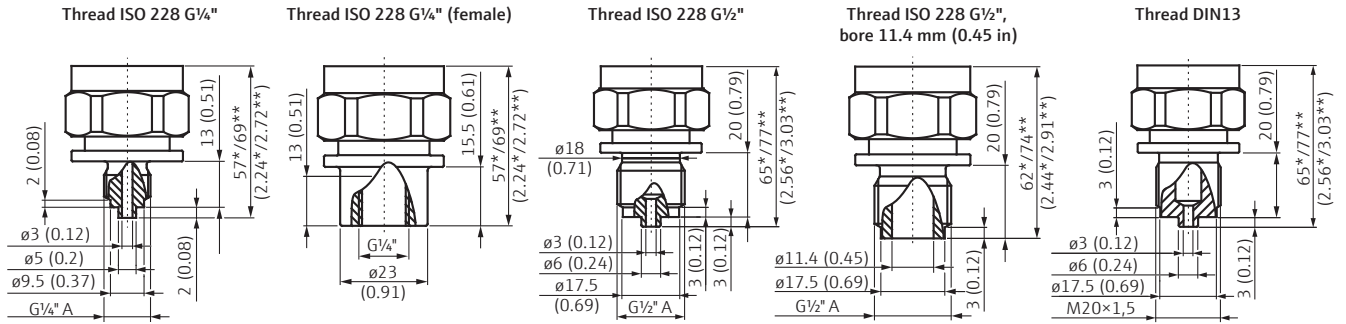

Process connections with flush-mounted, metallic process isolating diaphragm

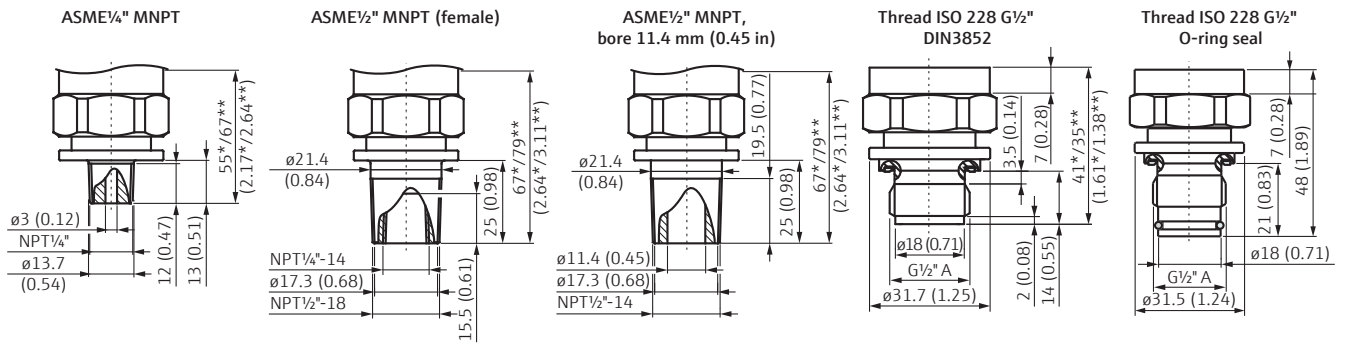

* to 100 bar (1500 psi) / ** 400 bar (6000 psi)

Electrical connection

4 to 20 mA output

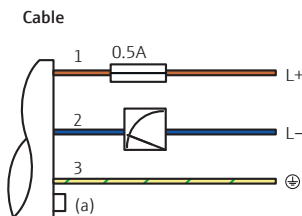
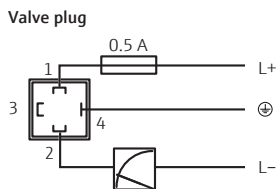
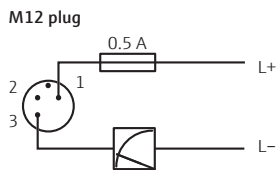

0 to 10 V output

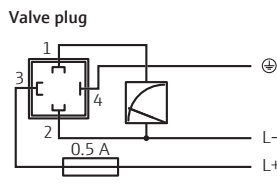
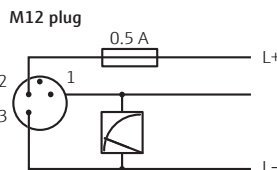

Cable:
 1: brown = L+
 2: blue = L-
 3: green/yellow = ground connection
 (a): reference air hose

Price table

Electrical connection

Code	Plug
L	Plug M12
U	Valve plug M16
V	Valve plug NPT½"

Sensor range

Code	Range (relative)
1F	400 mbar/40 kPa/6 psi, overload: 1.6 bar/160 kPa/24 psi
1H	1 bar/100 kPa/15 psi, overload: 4 bar/400 kPa/60 psi
1K	2 bar/200 kPa/30 psi, overload: 10 bar/1 MPa/150 psi
1M	4 bar/400 kPa/60 psi, overload: 16 bar/1.6 MPa/240 psi
1N	6 bar/600 kPa/90 psi, overload: 24 bar/2.4 MPa/360 psi
1P	10 bar/1 MPa/150 psi, overload: 40 bar/4 MPa/600 psi
1Q	16 bar/1.6 MPa/240 psi, overload: 64 bar/6.4 MPa/960 psi
1R	25 bar/2.5 MPa/375 psi, overload: 100 bar/10 MPa/1500 psi
1S	40 bar/4 MPa/600 psi, overload: 160 bar/16 MPa/2400 psi

Calibration, unit

Code	Version
B	Sensor range; mbar/bar/psi
J	Customized; please specify measuring range in your order

Seal

Code	Version
A	FKM
J	EPDM

Cerabar PMC11

Output	Process connection	Order no.	Price/pcs. in €		
			1 to 3	4 to 10	11 to 35
4 to 20 mA	Thread ISO228 G½" (internal)	PMC11-AA1 <input type="checkbox"/> <input type="checkbox"/> <input type="checkbox"/> WAJ <input type="checkbox"/>	176.-	158.-	144.-
	Thread ISO228 G½" EN837	PMC11-AA1 <input type="checkbox"/> <input type="checkbox"/> <input type="checkbox"/> WBJ <input type="checkbox"/>	176.-	158.-	144.-
	Thread ISO228 G½" EN837	PMC11-AA1 <input type="checkbox"/> <input type="checkbox"/> <input type="checkbox"/> WTJ <input type="checkbox"/>	176.-	158.-	144.-
	Thread ISO228 G½", bore 11.4 mm (0.45 in)	PMC11-AA1 <input type="checkbox"/> <input type="checkbox"/> <input type="checkbox"/> WWJ <input type="checkbox"/>	176.-	158.-	144.-
0 to 10 V	Thread ISO228 G½" (internal)	PMC11-AA2 <input type="checkbox"/> <input type="checkbox"/> <input type="checkbox"/> WAJ <input type="checkbox"/>	176.-	158.-	144.-
	Thread ISO228 G½" EN837	PMC11-AA2 <input type="checkbox"/> <input type="checkbox"/> <input type="checkbox"/> WBJ <input type="checkbox"/>	176.-	158.-	144.-
	Thread ISO228 G½" EN837	PMC11-AA2 <input type="checkbox"/> <input type="checkbox"/> <input type="checkbox"/> WTJ <input type="checkbox"/>	176.-	158.-	144.-
	Thread ISO228 G½", bore 11.4 mm (0.45 in)	PMC11-AA2 <input type="checkbox"/> <input type="checkbox"/> <input type="checkbox"/> WWJ <input type="checkbox"/>	176.-	158.-	144.-

* Please add code for electrical connection, sensor range, calibration and seal.

Accessories

	Order no.	Price/pcs. in €		
Weld-in adapter G½, 316L	52002643		53.02	
Weld-in adapter G1, 316L	52010171		125.30	
Straight plug, without cable (self wired)	52006263		15.55	
5 m cable with M12×1 plug	52010285		7.25	
M12×1 plug angled	71114212		25.41	
Display PHX20 for Cerabar with analog output	52022914	144.-	134.-	127.-

Electrical connection

Code	Plug
L	Plug M12
U	Valve plug M16
V	Valve plug NPT1/2"

Sensor range

Code	Range (relative)
1F	400 mbar/40 kPa/6 psi, overload: 1.6 bar/160 kPa/24 psi
1H	1 bar/100 kPa/15 psi, overload: 4 bar/400 kPa/60 psi
1K	2 bar/200 kPa/30 psi, overload: 10 bar/1 MPa/150 psi
1M	4 bar/400 kPa/60 psi, overload: 16 bar/1.6 MPa/240 psi
1N	6 bar/600 kPa/90 psi, overload: 24 bar/2.4 MPa/360 psi
1P	10 bar/1 MPa/150 psi, overload: 40 bar/4 MPa/600 psi
1Q	16 bar/1.6 MPa/240 psi, overload: 64 bar/6.4 MPa/960 psi
1R	25 bar/2.5 MPa/375 psi, overload: 100 bar/10 MPa/1500 psi
1S	40 bar/4 MPa/600 psi, overload: 160 bar/16 MPa/2400 psi

Calibration, unit

Code	Version
B	Sensor range; mbar/bar/psi
J	Customized; please specify measuring range in your order

Cerabar PMP11

Output	Process connection	Order no.	Price/pcs. in €		
			1 to 3	4 to 10	11 to 35
4 to 20 mA	Thread ISO228 G1/4" (internal)	PMP11-AA1 <input type="checkbox"/> <input type="checkbox"/> <input type="checkbox"/> WAJ	173.-	155.-	142.-
	Thread ISO228 G1/2" EN837	PMP11-AA1 <input type="checkbox"/> <input type="checkbox"/> <input type="checkbox"/> WBJ	173.-	155.-	142.-
	Thread ISO228 G1/2", flush-mounted	PMP11-AA1 <input type="checkbox"/> <input type="checkbox"/> <input type="checkbox"/> WJJ	173.-	155.-	142.-
	Thread ISO228 G1/4" EN837	PMP11-AA1 <input type="checkbox"/> <input type="checkbox"/> <input type="checkbox"/> WTJ	173.-	155.-	142.-
	Thread ISO228 G1/2", bore 11.4 mm (0.45 in)	PMP11-AA1 <input type="checkbox"/> <input type="checkbox"/> <input type="checkbox"/> WWJ	173.-	155.-	142.-
0 to 10 V	Thread ISO228 G1/4" (internal)	PMP11-AA2 <input type="checkbox"/> <input type="checkbox"/> <input type="checkbox"/> WAJ	173.-	155.-	142.-
	Thread ISO228 G1/2" EN837	PMP11-AA2 <input type="checkbox"/> <input type="checkbox"/> <input type="checkbox"/> WBJ	173.-	155.-	142.-
	Thread ISO228 G1/2", flush-mounted	PMP11-AA2 <input type="checkbox"/> <input type="checkbox"/> <input type="checkbox"/> WJJ	173.-	155.-	142.-
	Thread ISO228 G1/4" EN837	PMP11-AA2 <input type="checkbox"/> <input type="checkbox"/> <input type="checkbox"/> WTJ	173.-	155.-	142.-
	Thread ISO228 G1/2", bore 11.4 mm (0.45 in)	PMP11-AA2 <input type="checkbox"/> <input type="checkbox"/> <input type="checkbox"/> WWJ	173.-	155.-	142.-

* Please add code for electrical connection, sensor range and calibration.

Accessories

Accessories	Order no.	Price/pcs. in €		
Weld-in adapter G1/2, 316L	52002643		53.02	
Weld-in adapter G1, 316L	52010171		125.30	
Straight plug, without cable (self wired)	52006263		15.55	
5 m cable with M12x1 plug	52010285		7.25	
M12x1 plug angled	71114212		25.41	
Display PHX20 for Cerabar with analog output	52022914	144.-	134.-	127.-

Prices are applicable for Germany until 30/06/2020, in Euro per unit, net excluding value added tax (VAT), cost of packing and dispatch. Endress+Hauser retains the right to change or modify pricing at any time. The terms of sales and delivery of Endress+Hauser are applicable. Current prices and delivery times can be verified prior to ordering on www.e-direct.endress.com.



Complete product information:
www.e-direct.endress.com/pmx11

More products to complete your measuring point ...



Capacitive probe
Liquicap T FMI21



Temperature sensor
iTHERM ModuLine TM101



Process transmitter
RMA42